

TAKER B70 WHITE & IR

480-880-960

INSTALLATION GUIDE

TAKER B70 WHITE & IR REFERENCE GUIDE

LIGHT HEAD

(WITH PROTECTIVE COVER ON)

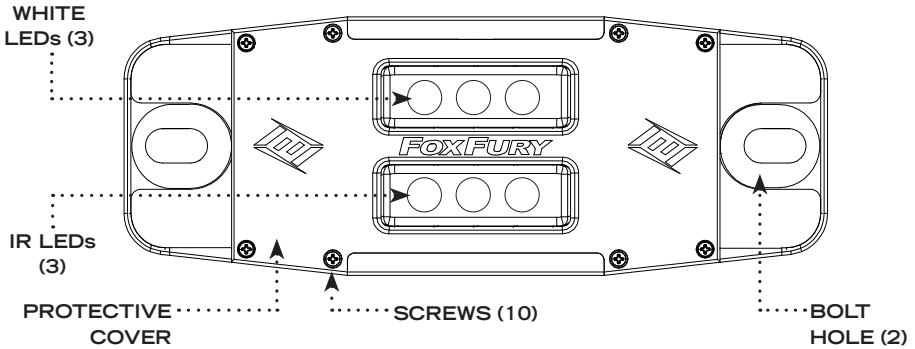

LIGHT HEAD

(WITH PROTECTIVE COVER OFF)

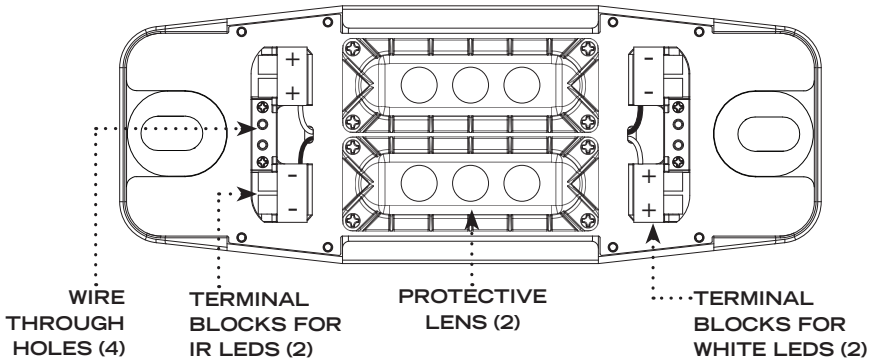

HANDLE

(BACK SIDE)

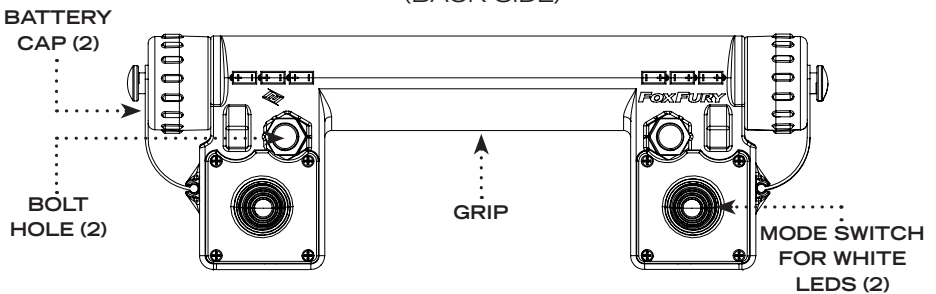

HANDLE (FRONT SIDE)

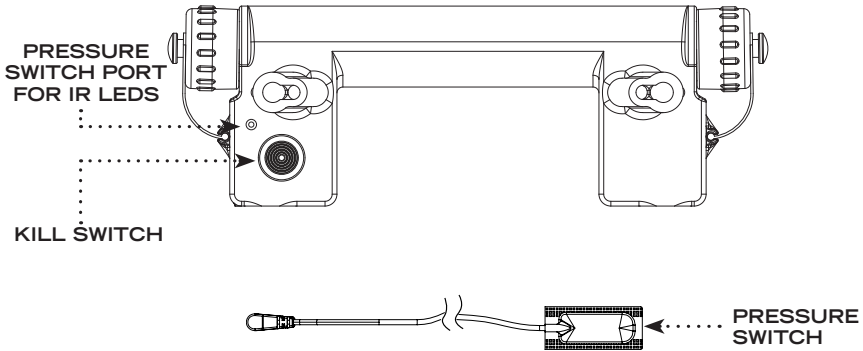

WHAT'S INCLUDED

- ❖ Taker B70 White & IR Light Head (P/N 600-480-880-960)
- ❖ Taker B70 Handle with Electronics & Pressure Switch (P/N 60-601)
- ❖ Washers (2)
- ❖ Sleeves (2) – To be used with 5/16"-18 Bolts Only
- ❖ Foams (2) – To be used with Flat Shield Only

ITEMS REQUIRED

- ❖ Grade 8 Bolt (2 each): 5/16"-18 or 3/8"-16
Bolt Length: 97 mm plus shield thickness
- ❖ Nut (4 each): 5/16"-18 or 3/8"-16
- ❖ Wrench or Socket: 1/2" or 9/16"

INSTALLATION

The B70 is intended to be installed as an OEM product, by ballistic shield and armor manufacturers.

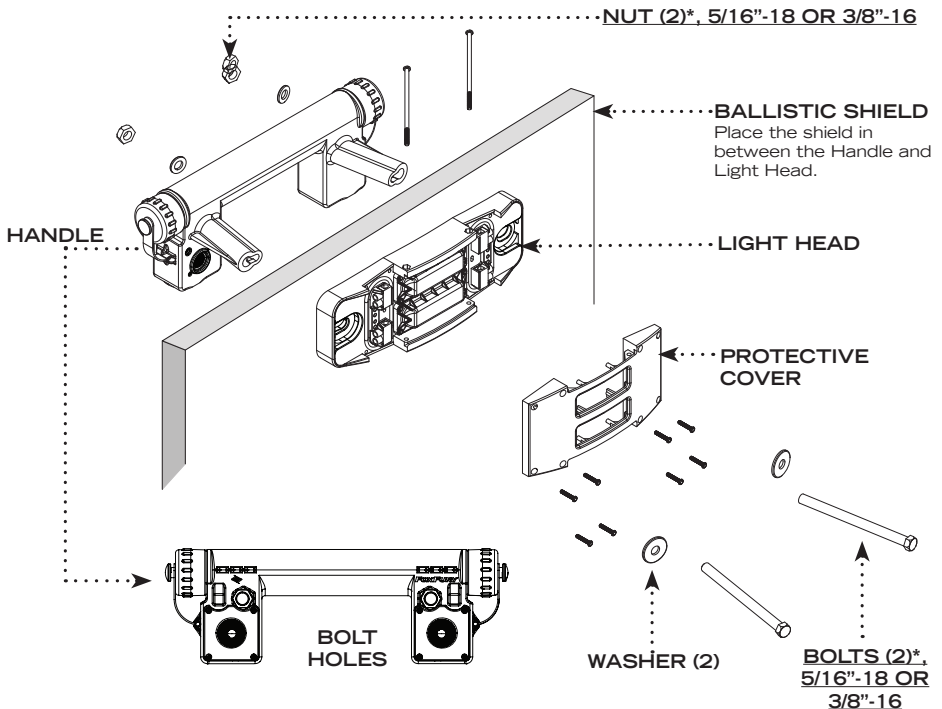

1 Begin by drilling two holes into the shield. To do this, locate the Bolt Hole(s) (2) located on the **BACK SIDE** of the Handle (shown above).

HELPFUL TIP: Use a #2 pencil (or a tool of the same diameter) and insert it through the Bolt Holes (of the **BACK SIDE** of the Handle) to draw two marks on the shield. This will help when determining placement of the holes when drilling.

The center-center bolt distance measured from the Handle at the ring terminal is 165mm. Drill holes at a diameter to match your bolt size, and the tolerances that you designate.

IMPORTANT:

* The underlined items above are **NOT** included and must be supplied by the shield manufacturer.

** When using 5/16"-18 Bolt, install the supplied Sleeve in each Handle. When using 3/8"-16 Bolt, the Sleeves are not needed for installation.

2 Once both holes are drilled through the shield, it is important to drill two small holes (4 mm diameter) next to each Bolt Hole, so that the wires can be fed through the shield. See p. 5 - 6 for wiring installation.

WIRING INSTALLATION

1

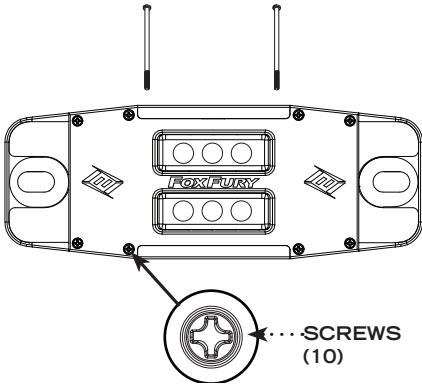

2

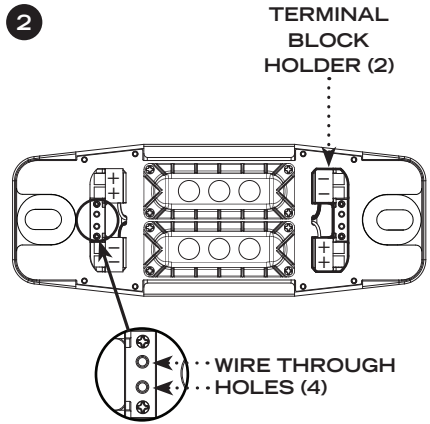

3

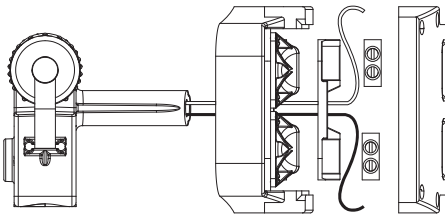

4

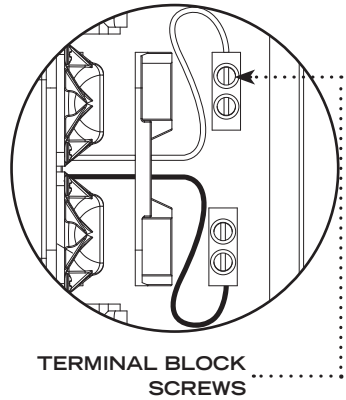

5

WIRE CONNECTION FOR IR

WIRE CONNECTION FOR WHITE

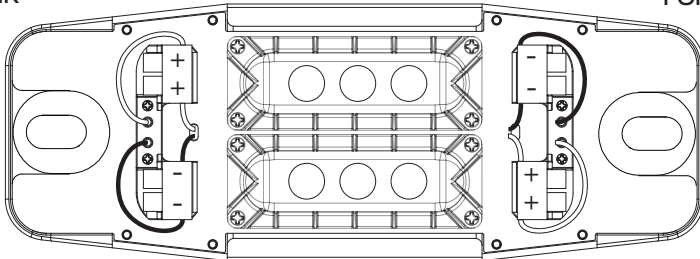

1 Begin with the Light Head and a Phillips Head Screw Driver. There are eight (8) Screws located on the front of the Protective Cover, and two (2) Screws on the top of the Light Head. Remove all ten (10) Screws from the Protective Cover.

2 Once the Protective Cover is removed, the inner workings of the Light Head will be exposed. Next, find the Wire Through Holes (this will be where the red and black wires will come through; the red and black wires are located within the Handle).

❖ The Terminal Block Holder can be removed by removing the two (2) top and bottom screws on each side. This makes it easier to pull the wires through in Step 3.

NOTE: the location of the Terminal Block Holder can be seen in Step 2 of "Wiring Installation."

3 View the Light Head and Handle from the side. Make sure the orientation of the Light Head is correct by matching the W (white) and IR markings on the back of the Light Head and the markings on the red and black wires on the Handle. Then, bring the Handle close to the back of the Light Head. Using the diagram in Step 2, take the red wire from the Handle and feed it through the back of the Light Head and through the wire hole. Repeat with the black wire from the Handle.

❖ Note that the diagram in Step 3 shows that the top Wire Through Hole is for the red wire and that the bottom Wire Through Hole is for the black wire. This is for IR wires. It is opposite for White LED wires.

4 Once the red and black wires are fed from the Handle (on both sides) through the Light Head, loosen the screws on all four (4) of the Terminal Blocks. Use a flat head screw driver to loosen the screws. Then insert the respective wire into the side of the Terminal Block and re-tighten the screw to secure the wire. Repeat on the other three (3) Terminal Blocks.

❖ IMPORTANT: Reinstall the Terminal Block Holder by replacing the screws and tightening.

❖ Once all wires are installed completely, install batteries and test the light's performance by deactivating the Kill Switch and pressing Power/Mode Switch on either Handle.

CAREFULLY begin to pull all the wires tight. This will make it easier to reinstall the Protective Cover in the next step.

5 After pulling all wires tight, reinstall the Protective Cover onto the Light Head. In the instance that the wires could not be pulled tight enough (as mentioned above, then this could take a few minutes, as the wires may not easily be tucked under the Protective Cover. Once the Protective Cover is placed back on, reinstall all ten (10) screws to secure it.

